



Integrated Amplifier  
M-100 USER'S MANUAL



version 1.3

MICROMEGA

Le son de France

# MICROMEGA

## RESEARCH, INNOVATE, CREATE

*"Whenever I speak about my company I speak with the passion we have. Located in the Paris region of France, I have ensured that Micromega has the best elements of my industrial group at their availability. In an age where music is dematerializing, we are committed to staying at the forefront of technology and growing under our 'made in France' banner.*

*The M-one programme, with its incredible audio quality, technical capacity and sleek design represents a major advance in the history of our company. The result of three years of research by our team, we are proud to introduce to you what we believe is the most effective and complete integrated stereo amplifier of its kind.*

*Micromega is synonymous with technological advances, expertise, reliability and sound clarity. All of our products reflect these demands."*

*Didier HAMDI, CEO Micromega*



### The advantages of the M-One amplifier series :

- High quality, A/B class amplification
- Resonant power supply
- Symmetrical design
- Asahi Kasei AK4490 DAC converter
- Acoustic correction in situ using ROOM EQ (included or as an option)
- Binaural processing of the headphone output (included or as an option)
- Cover and remote control machined from aluminium block
- Android and iOS compatible control app

# MICROMEGA

Le son de France

<b>1 - OVERVIEW</b> .....	4	2.9	I <sup>2</sup> S input .....	19
1.1 Front and top .....	4	2.10	LAN connection .....	20
1.2 Back .....	5	2.11	Speaker connections .....	21
1.3 Sides (ventilation) .....	6	2.12	Connecting headphones .....	22
1.4 Bottom .....	7	2.13	Subwoofer output .....	23
1.5 Infrared remote control .....	8	2.14	Pre-out .....	24
1.5 Changing the IR Remote battery .....	9	2.15	Trigger sockets .....	25
<b>2 - CONNECTIONS</b> .....	10	2.16	Mains power supply .....	26
2.1 Phono input for a vinly turntable .....	10	2.17	Fuse .....	27
2.2 RCA line input .....	11	<b>3 - USER GUIDE</b> .....	28	
2.3 Balanced XLR analogue input .....	12	3.1 Starting up .....	28	
2.4 Coaxial digital input .....	13	3.2 Choosing your source .....	29	
2.5 Optical digital input .....	14	3.3 Adjusting the balance .....	30	
2.6 AES-EBU input .....	15	3.4 Adjusting sensitivity .....	31	
2.7 USB input (Type B) .....	16	3.5 Renaming the sources .....	32	
2.8 Bluetooth aptX connection .....	17	3.6 Updating the M-100 .....	33	
		3.7 Updating the network module .....	34	
		<b>4 - SPECIFICATIONS</b> .....	35	

# 1. OVERVIEW

Carefully check that the packaging is intact. If you feel it may have been tampered with or damaged please contact your vendor.

Carefully remove your device from the packaging. Store the packaging in a secure, dry place: if you need to return your device to the vendor you will require the original packaging.

## 1.1 FRONT AND TOP

The M-100 amplifier has two displays so that it can be controlled from any position. The displays will automatically adjust to whichever position the amplifier is in (e.g. flat, attached to wall).

There is a headphone socket on the front so that you can listen to your music in complete peace. A "Binaural" process (as an option) allows you to re-create the 3D sound scene through the headphones which is lost in classic stereophonic recordings.

On the top of the device are 4 buttons which you can use to adjust the reactions of your amplifier (see section 3.1 for more information).

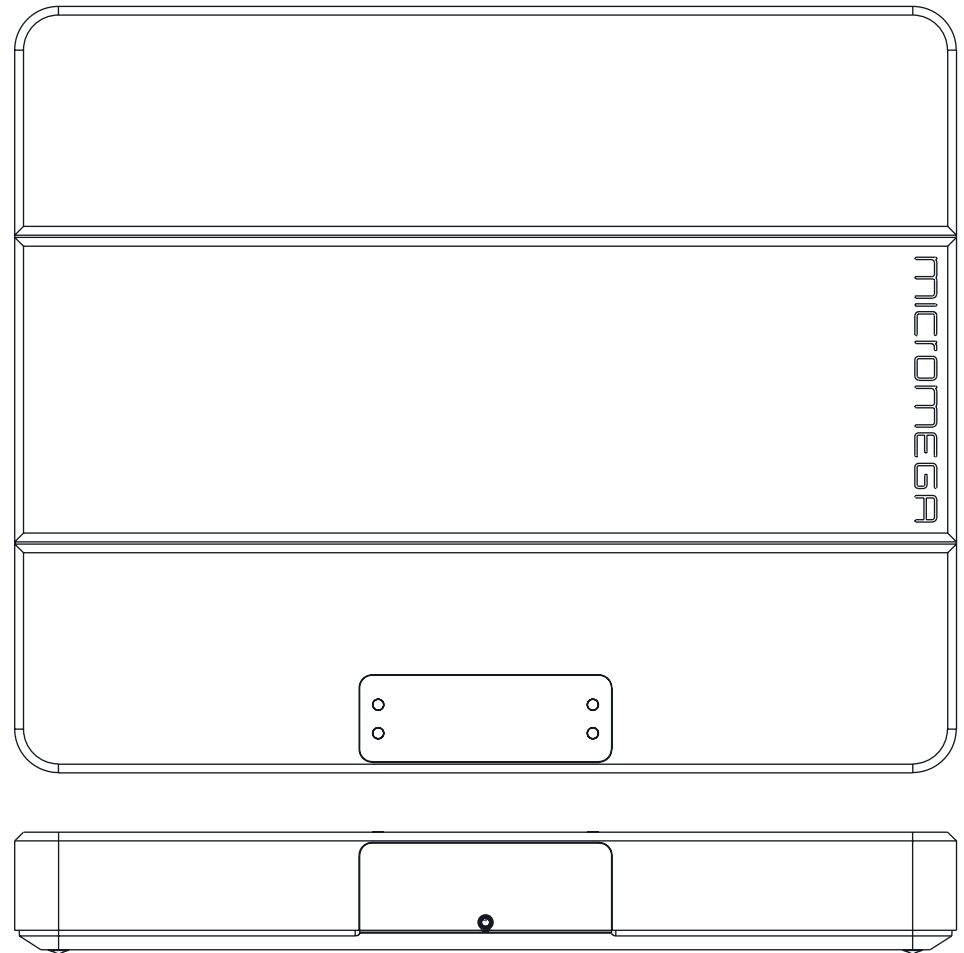

# 1.2 BACK

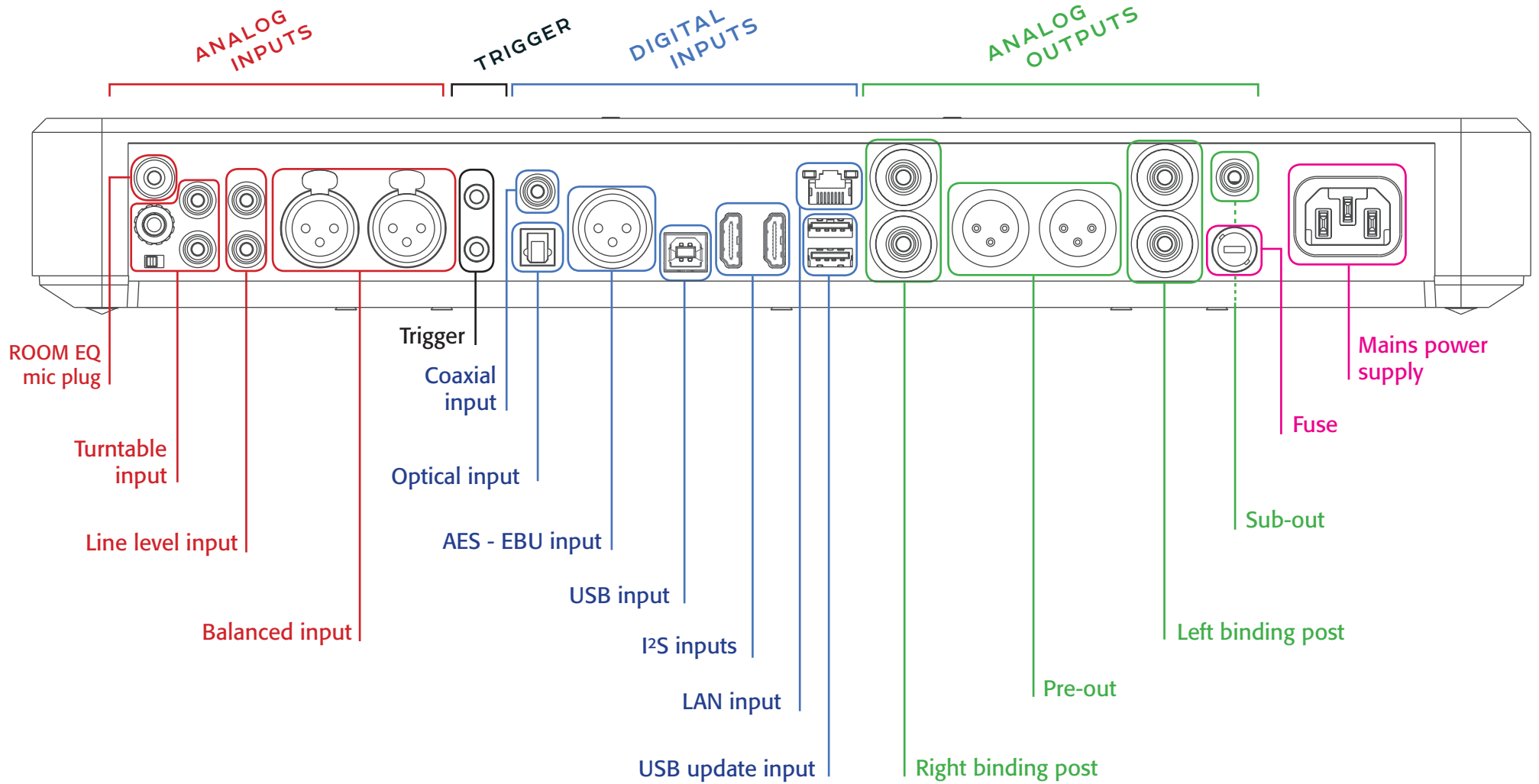

### 1.3 SIDES (VENTILATION)

The M-100 amplifier should be positioned so that it can receive sufficient ventilation. Do not obstruct the air vents on the side of your amplifier. You should leave at least 10cm of space around the air vents.

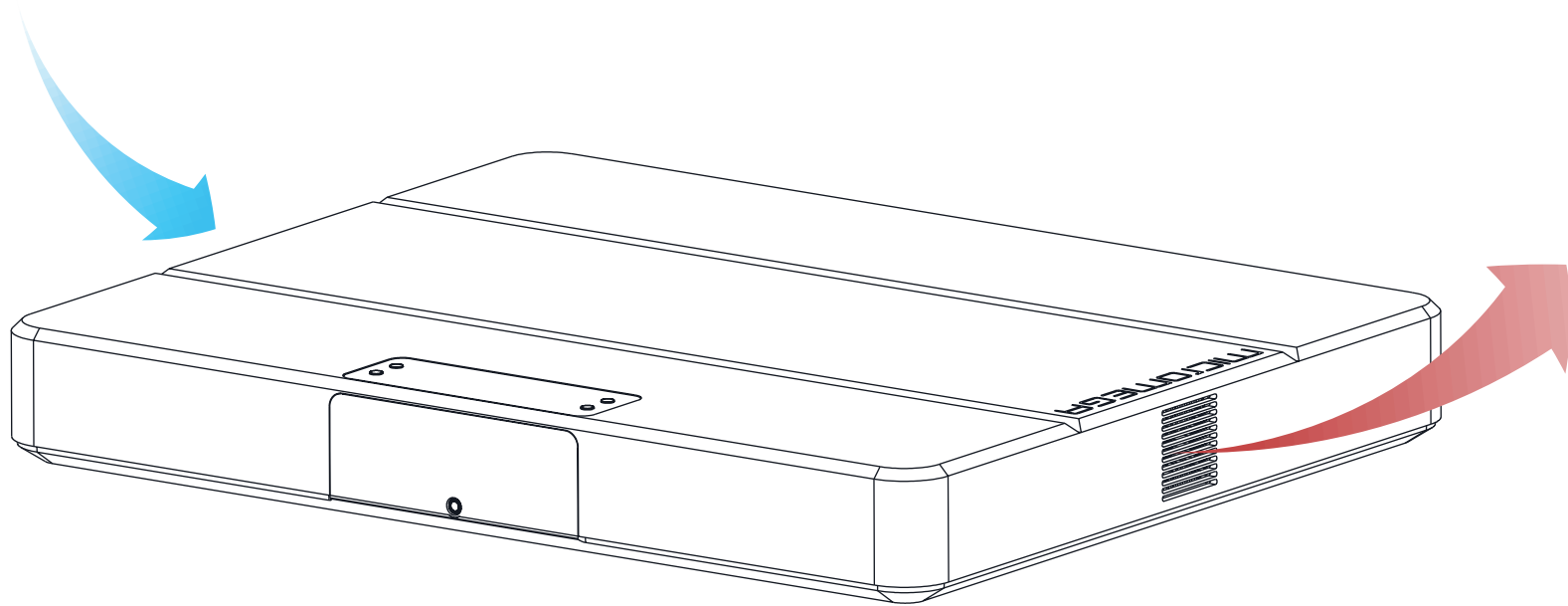

**⚠ We advise against placing the M-100 inside a closed furniture or space ⚠**

## 1.4 BOTTOM

You will find a connection guide under your M-100 amplifier which illustrates all of the input and output terminals available.

Take note that the M-100 has spiked feet. It can harm your furniture. Use the included rubber pads to avoid damage.

**⚠ Do not try to open the M-100 ⚠**

**⚡ It contains potentially  
life-threatening high voltage ⚡**

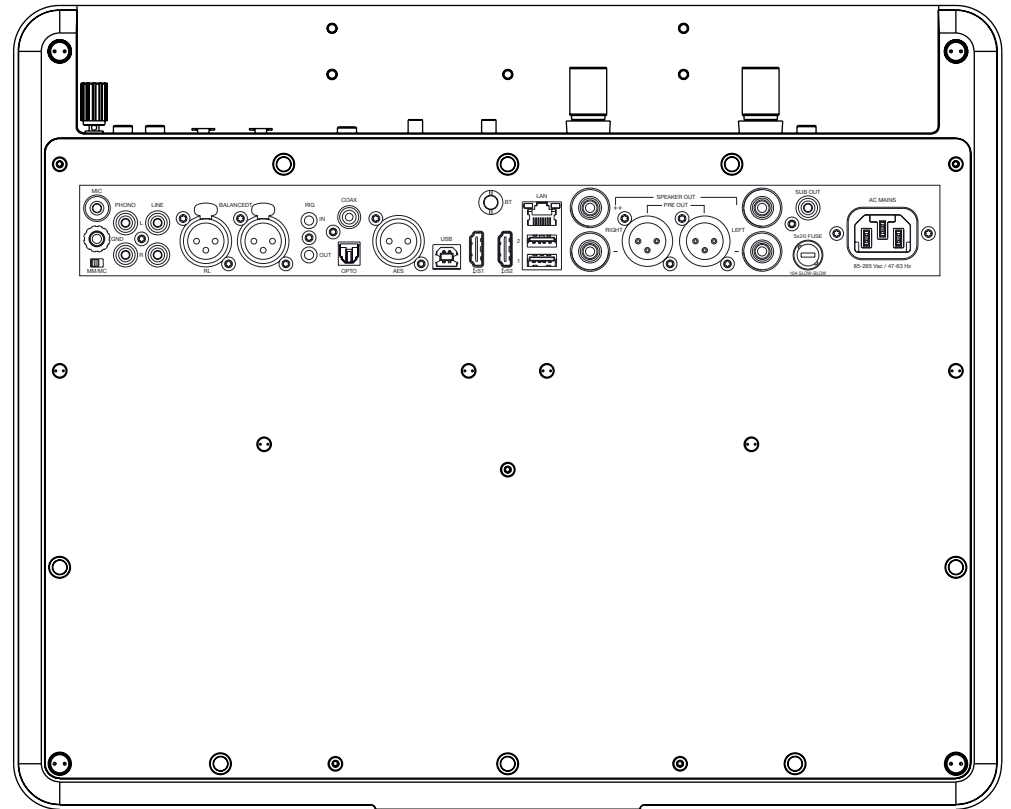



## 1.5 INFRARED REMOTE CONTROL

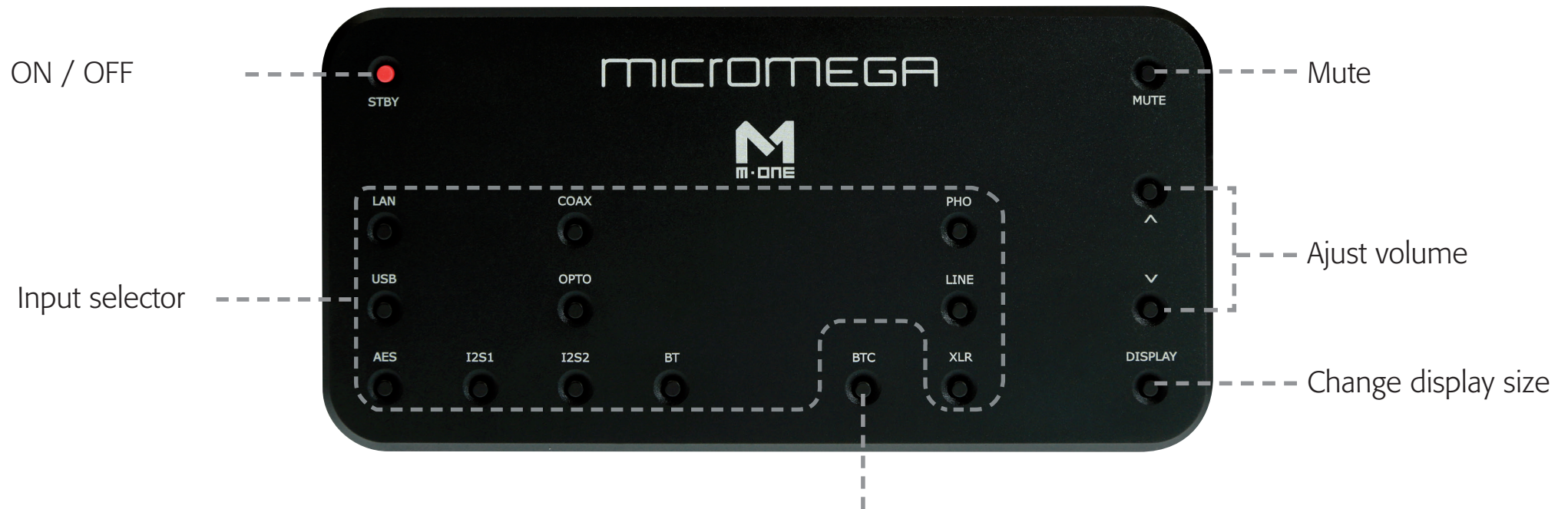

« Bluetooth Connect »

- Press and release : pairing will start
- Press and hold (for 10 seconds then release) : clear Bluetooth memory



## 1.6 CHANGING THE IR REMOTE BATTERY

Battery ref : CR2450N Lithium 3V

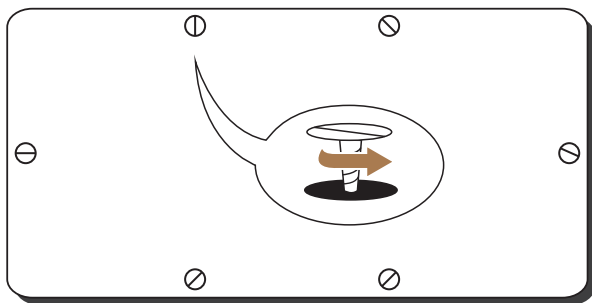

**1** Unscrew all the screws

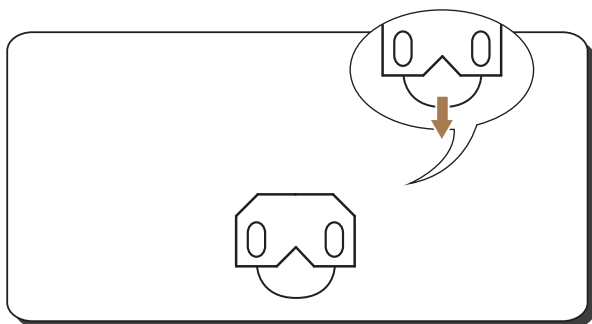

**2** Replace the old battery and insert the new one

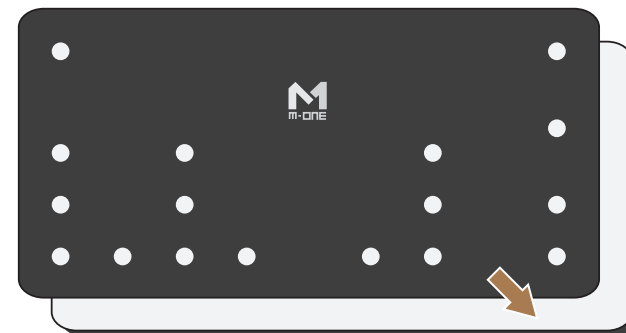

**3** Put the top cover back

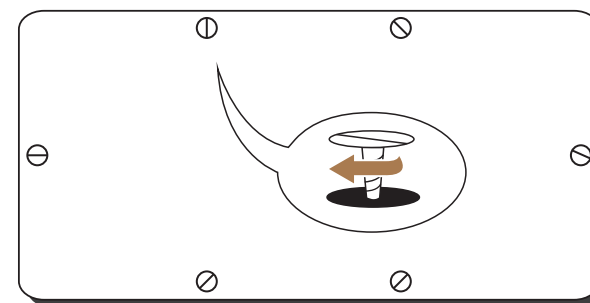

**4** Put the screws back !

## 2. CONNECTIONS

### 2.1 PHONO INPUT FOR A VINYL TURNTABLE

The « PHONO » input on the M-100 amplifier is compatible with MM and MC cartridges.

You can select the correct cartridge for your turntable using the switch located on the back of the amplifier.

- If your turntable has an MM cartridge, you should place the switch in the MM position
- If your turntable has an MC cartridge, you should place the switch in the MC position

There is a 'GND' grounding terminal near the Phono plugs so that you can connect the grounding terminal of your record player if necessary.

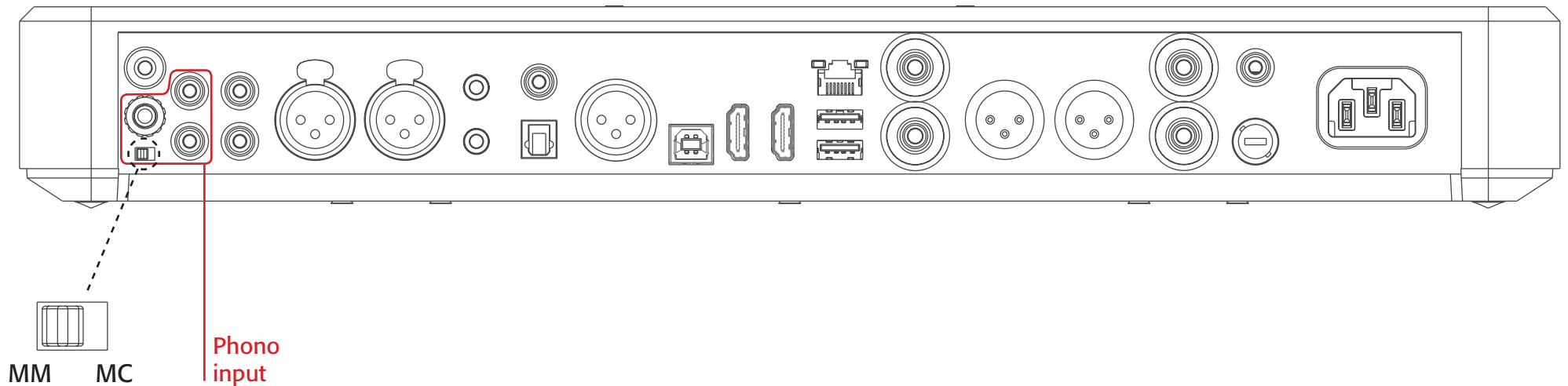

## 2.2 RCA LINE INPUT

The M-100's « LINE » input can be used to connect any device with RCA analogue output.

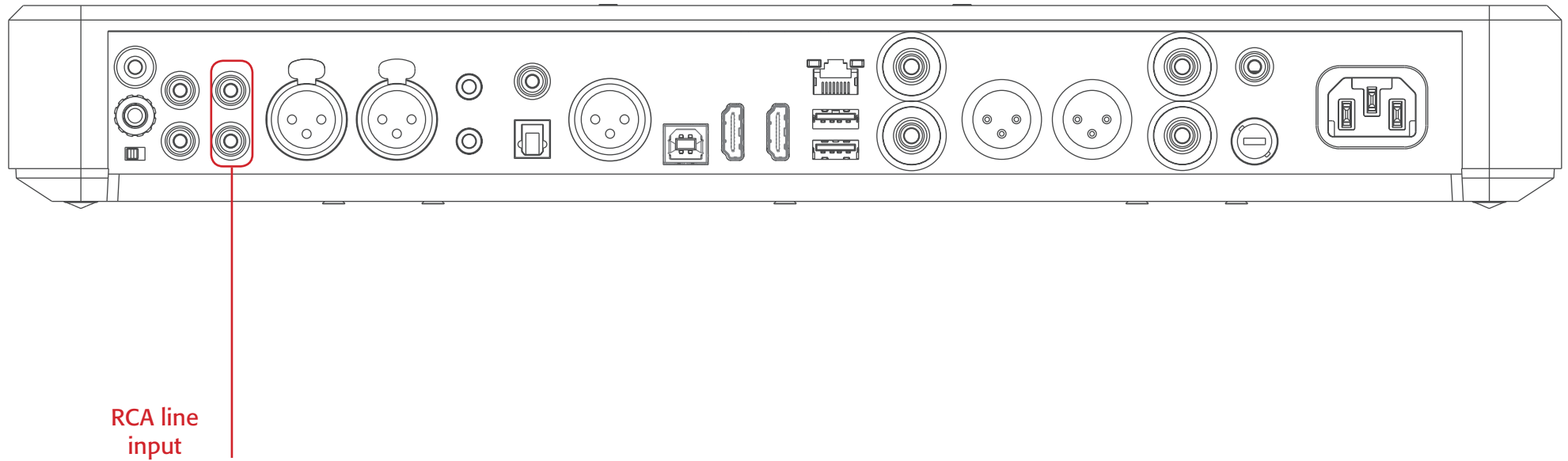

## 2.3 BALANCED XLR ANALOGUE INPUT

The M-100's « BALANCED » input can be used to connect any device with symmetrical analogue output.

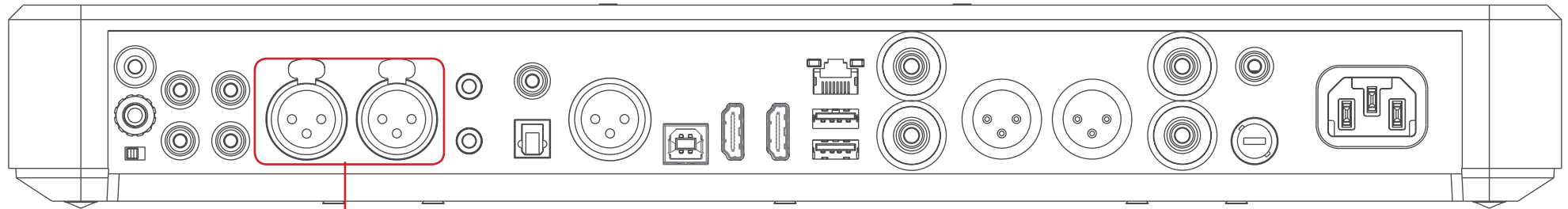

Balanced XLR  
analogue input

## 2.4 COAXIAL DIGITAL INPUT

The M-100's « COAX » input can be used to connect any device with an SPDIF coaxial output.

The signal should be a PCM stereo signal up to 32bit/768kHz.

**⚠ YOUR BLU-RAY OR DVD PLAYER MUST BE CONFIGURED  
IN PCM ON THE AUDIO OUTPUT**

**OTHERWISE IT COULD PRODUCE AN INTENSE NOISE  
IN YOUR SPEAKERS AND DAMAGE THEM ⚠**

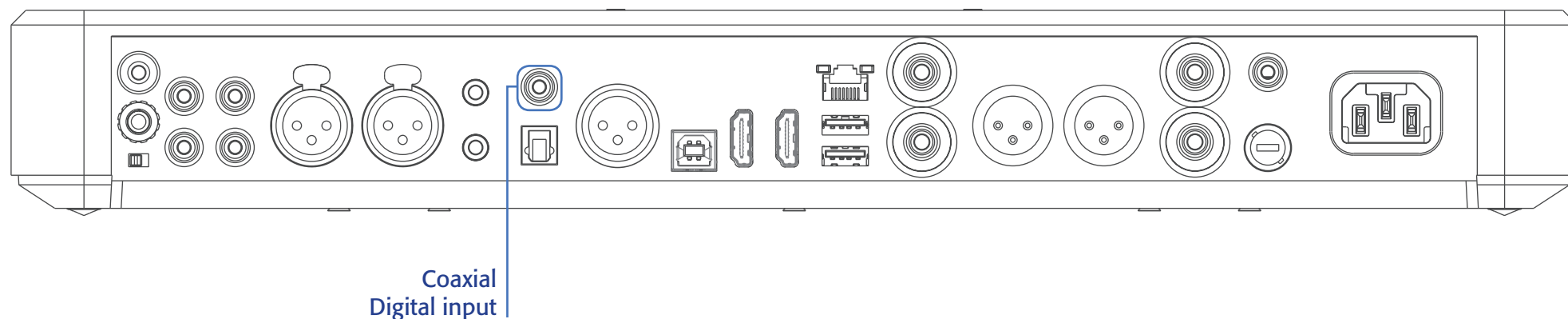

## 2.5 OPTICAL DIGITAL INPUT

The M-100's « OPTO » input can be used to connect any device with a Toslink digital connection.

The signal should be a PCM stereo signal up to 24bit/192kHz

**⚠ YOUR BLU-RAY OR DVD PLAYER MUST BE CONFIGURED  
IN PCM ON THE AUDIO OUTPUT**

**OTHERWISE IT COULD PRODUCE AN INTENSE NOISE  
IN YOUR SPEAKERS AND DAMAGE THEM ⚠**

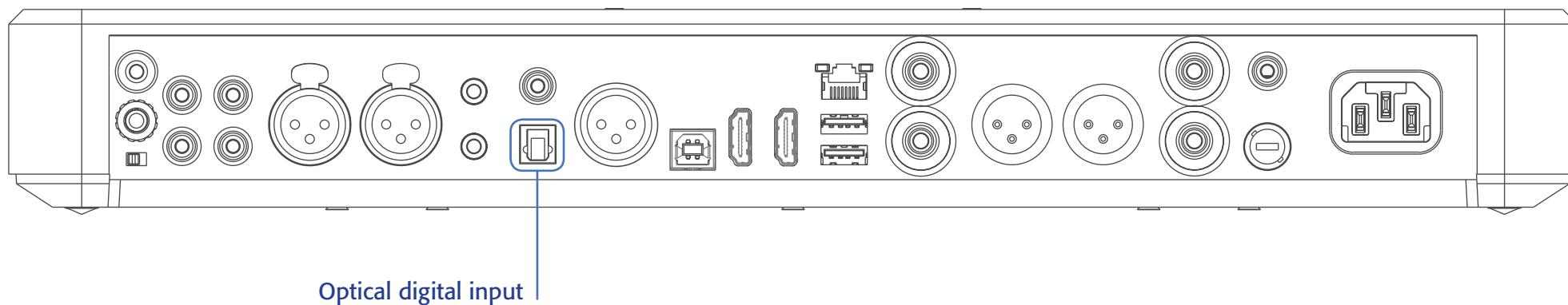



## 2.6 AES-EBU INPUT

The M-100's « AES » input can be used to connect any device with an AES-EBU connection on XLR.

The signal should be a PCM stereo signal up to 32bit/768kHz.

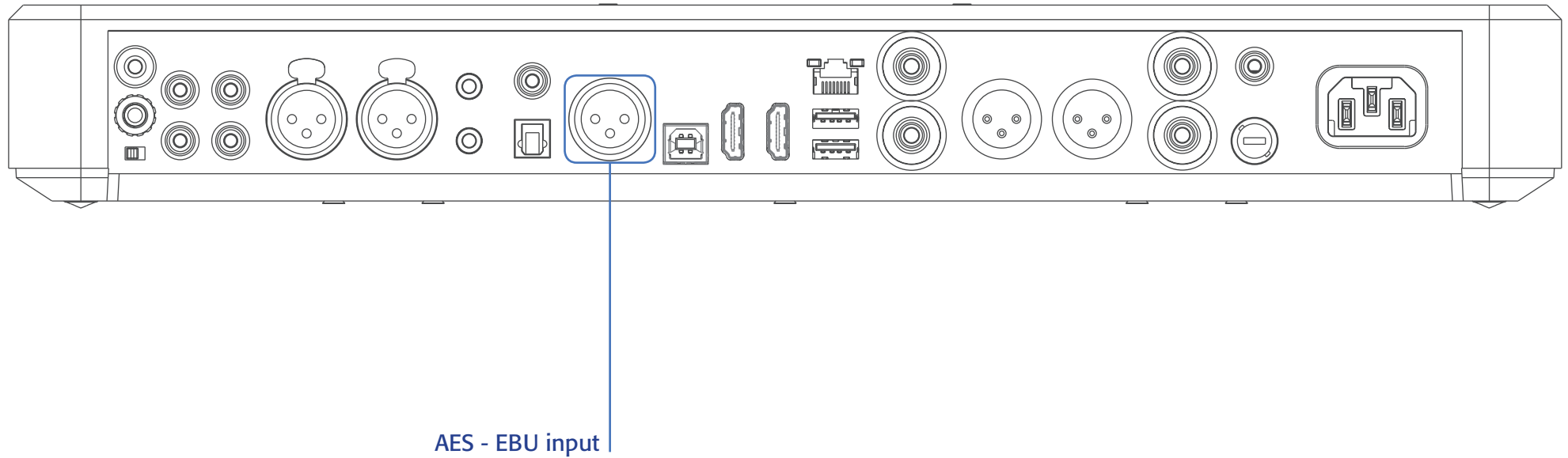

## 2.7 USB INPUT (TYPE B)

The M-100's « USB » input can be used to connect any computer with a USB port.

The signal should be a PCM stereo signal up to 32bit/768kHz or DSD/DSD-DoP up to 11.2MHz.

A USB driver will be required for any computer using Windows. You can download the driver from the M-One page on the Micromega website.

For computers using OS X or macOS you will not need an additional driver.

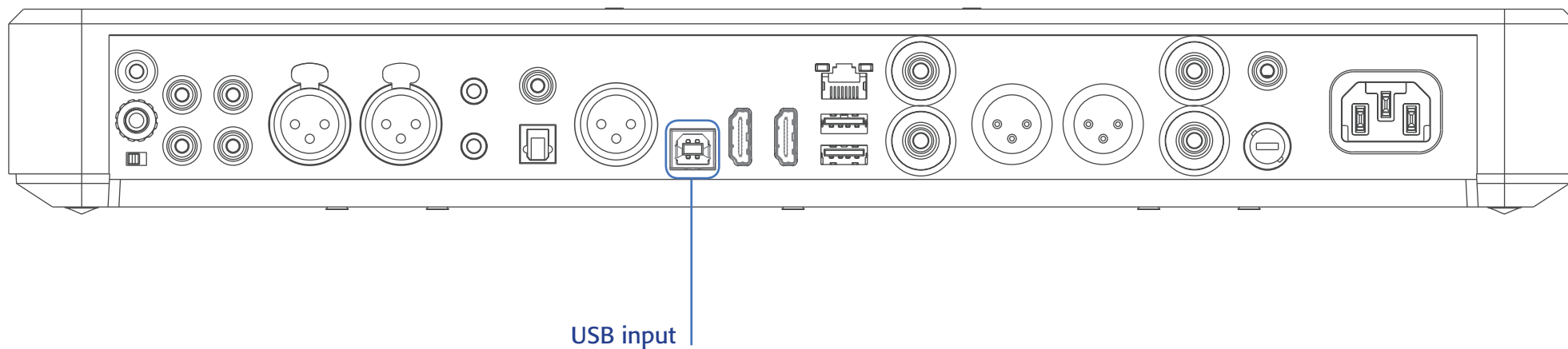

## 2.8 BLUETOOTH® APTX® CONNECTION

The M-100's « BT » connection can be used to wirelessly connect smartphones, tablets, computers or MP3 players with Bluetooth®. The Bluetooth® link is compatible with aptX® for the best sound quality. To make this manual easier to read, the term « Smartphone » will be used in this section to mean smartphones, tablets, computers and MP3 players.

### To connect via Bluetooth® for the first time:

- Ensure that the Bluetooth® function on your smartphone is turned on.
- Use the remote control to click on the 'BT' button.
- You should see the « M-ONE » appear on the list of Bluetooth® connections available on your smartphone. To establish a connection select the « M-ONE ».
- Launch music on your smartphone.

### To connect via Bluetooth® with a different smartphone, tablet etc.

- Ensure that the Bluetooth® function on your smartphone is turned on.
- Use the remote control to click on the 'BT' button.
- Then press release the « BTC » button on the remote control.
- You should see the « M-ONE » appear on the list of Bluetooth® connections available on your smartphone. To establish a connection select the « M-ONE ».
- Launch play on your smartphone.

**The following time you select the BT input :**

- If the Bluetooth® on your smartphone is turned on, the connection will work automatically once you select the 'BT' button on the amplifier using the remote.

**NB :** *Bluetooth® is a « point to point » connection. This means that if a tablet is already connected to the amplifier, you will not be able to connect your smartphone at the same time. You will need to disconnect your tablet from the amplifier before connecting your smartphone.*

## 2.9 I<sup>2</sup>S INPUT

The M-100's « I<sup>2</sup>S » inputs are ONLY TO BE USED with future Micromega products.

⚠ Only for use with MICROMEGA products ⚠

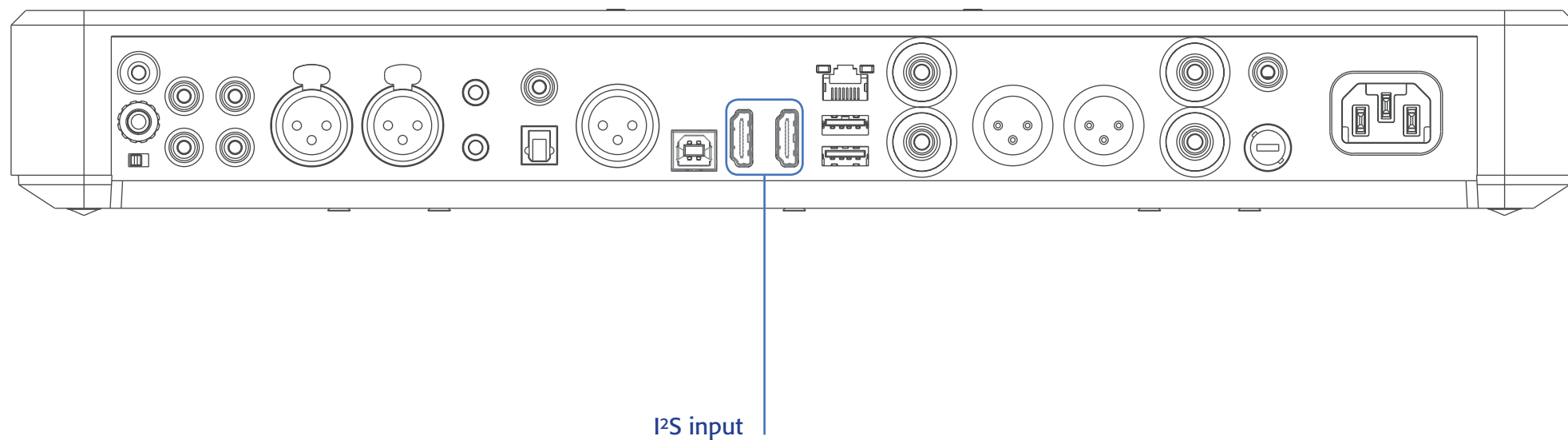

## 2.10 LAN CONNECTION

The M-100 can receive music via its network socket (LAN). In order to do this you must connect an Ethernet cable between your modem/router (Internet box) and the M-ONE.

You should use DLNA/UPnP compatible software (e.g. JRiver) on your computer to send music to the M-One.

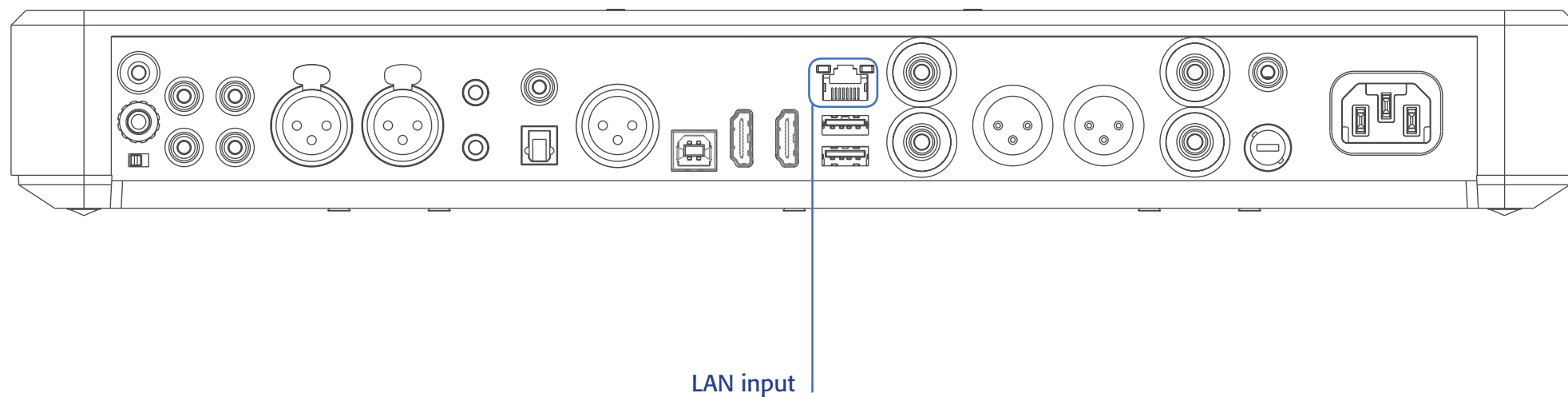



## 2.11 SPEAKER CONNECTIONS

The amplifier's terminal block is compatible with naked cables, banana plugs and fork plugs.

**Naked cables** : reveal approx. 10mm of naked cable. Unscrew the terminal block until there is a gap and insert the cable. Screw the block back into place

**Banana plugs** : once you have attached the banana plugs to the cable, insert the plug into the centre of the terminal.

**Fork plugs** : once you have attached the fork plugs to the cable, unscrew the terminal block until there is space to insert each fork plug. Screw the block back into place

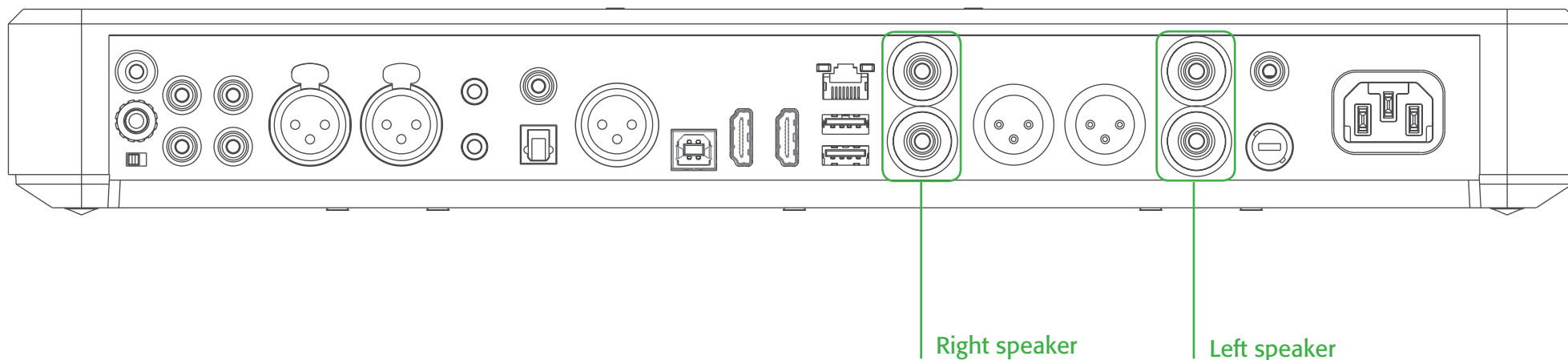

## 2.12 CONNECTING HEADPHONES AT THE FRONT OF THE AMPLIFIER

You can connect headphones at the front of the amplifier using a 3.5mm mini-jack. If your headphones have a 6.35mm jack then you will need to use an adapter.

Once headphones are connected to the front the speakers are rendered inactive. The headphone and speaker volume controls are separate and memorised independently.

This headphone terminal is compatible with the « binaural » process which is available as an option. Micromega has researched HTRF (Head Related Transfer Function) in order to reproduce the original sound scene (in front of you).

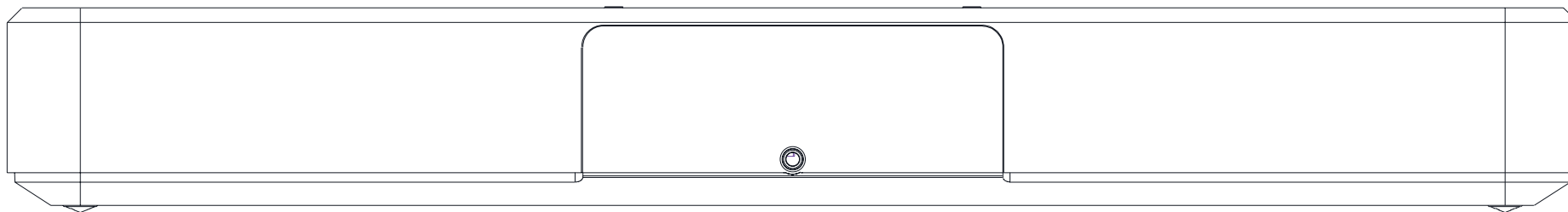

## 2.13 SUBWOOFER OUTPUT

You can connect a Subwoofer to the RCA Sub-Out input. This input has a low pass filter with a limiting frequency of 400 Hz. You should control the cutoff frequency and the volume using the control panel on your subwoofer.

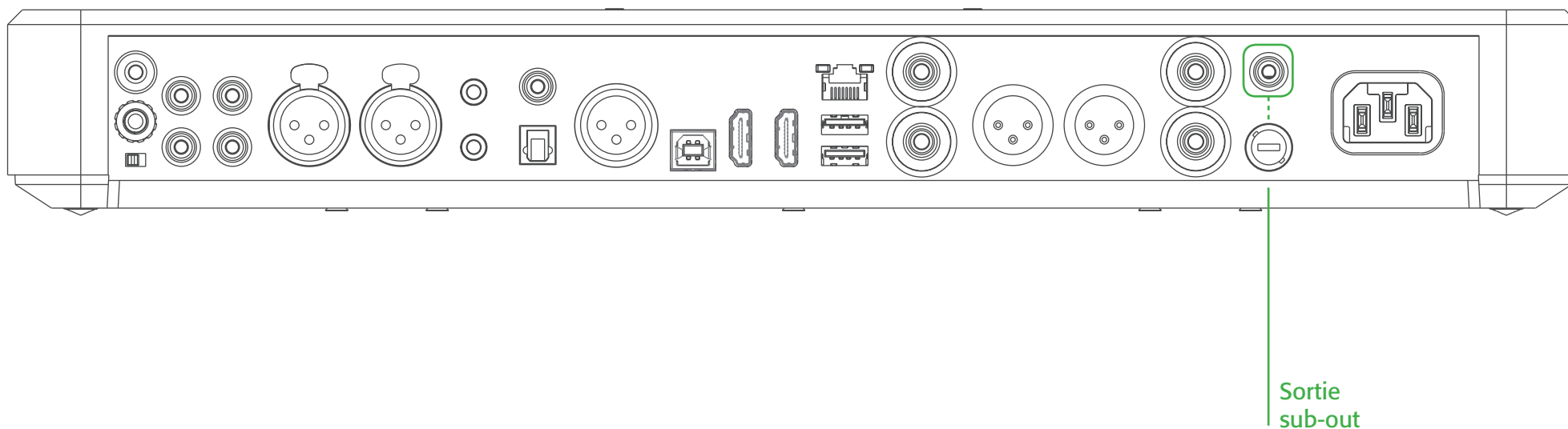

## 2.14 PRE-OUT LINE OUT

If you are using an external power amplifier, please use XLR cables to connect it to the Pre-out terminals.  
The volume of the Pre-Out terminals is variable and follows the volume indicated on your M-100 amplifier.

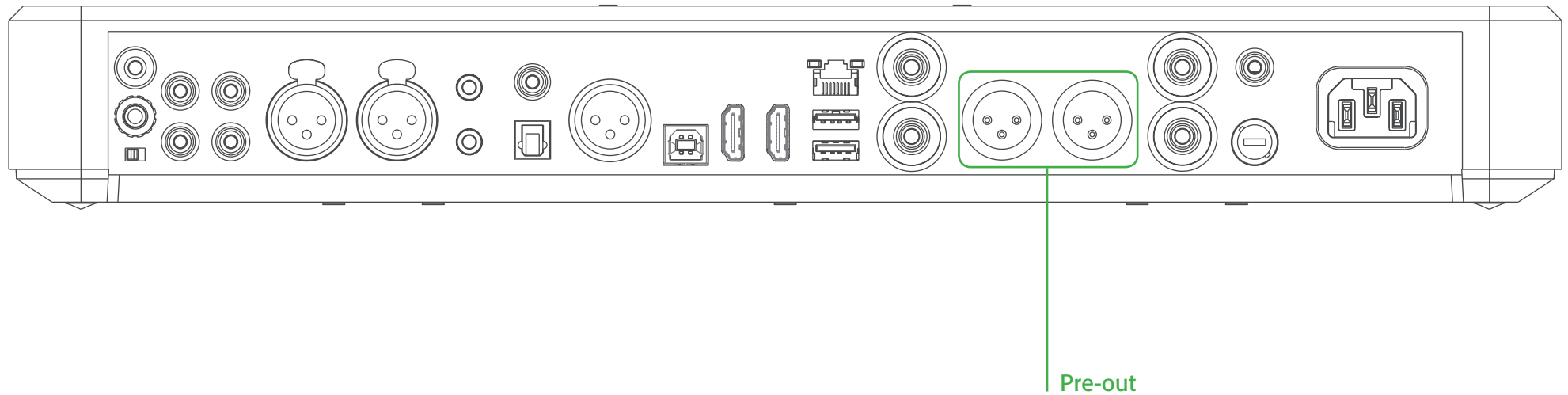

## 2.15 TRIGGER SOCKETS

Trigger sockets enable the use of the amplifier as part of a home automation system.

**Trigger IN :** Can be used with control voltages from 5 to 12V. The amplifier turns on when this voltage is running through it and off when it isn't.

**Trigger OUT :** When the amplifier is turned on there are 5V running through the Trigger OUT terminal.

⚠ Use 3.5 mm mono mini-jack sockets ⚠

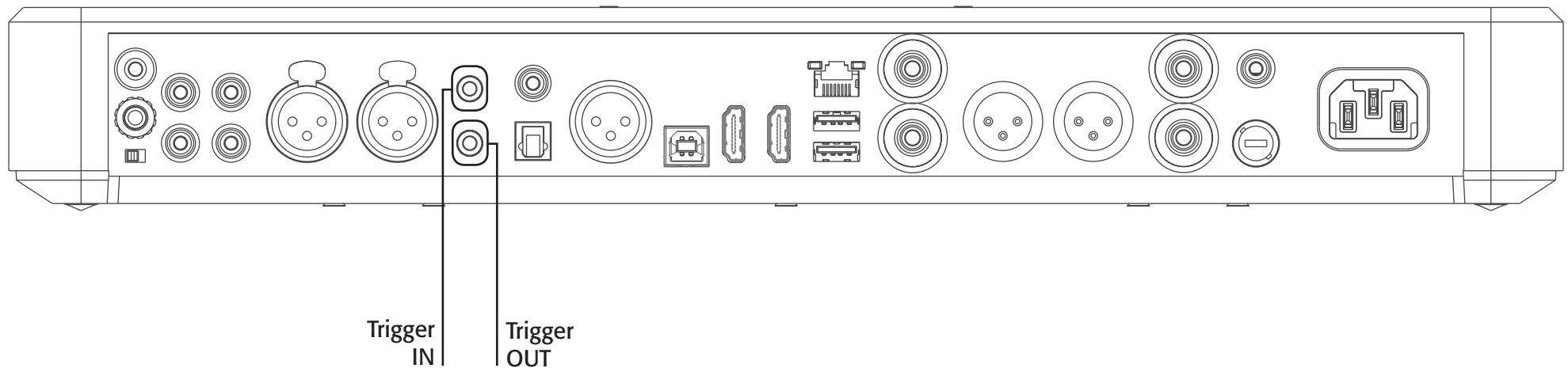

## 2.16 MAINS POWER SUPPLY

We recommend you connect all of your music sources and speakers before connecting the power supply.

Use the power cable supplied with your amplifier.

⚠ Check that the mains supply on the label (packaging or underneath the device) matches the mains supply in situ. ⚠

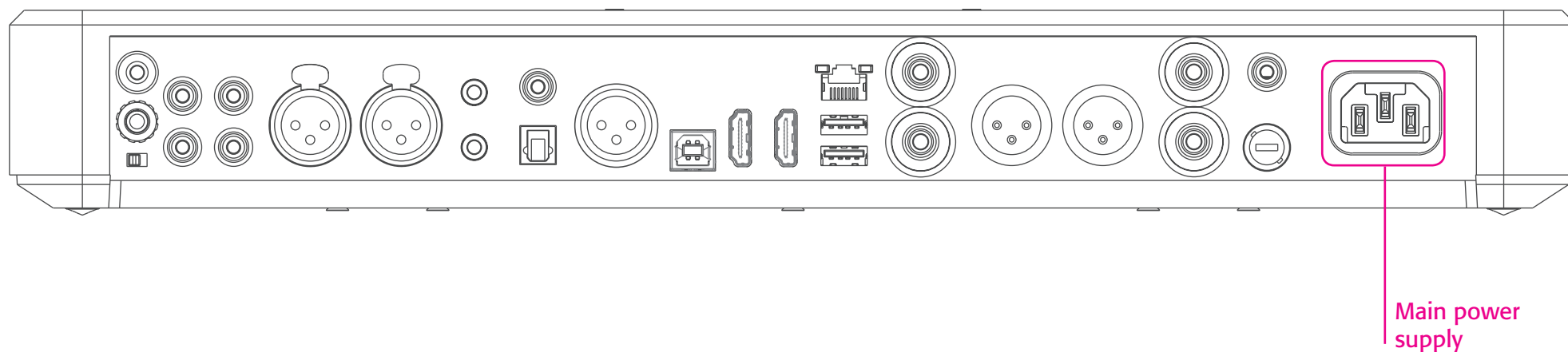





## 3. USER GUIDE

### 3.1 STARTING UP

Once you have attached all of your music sources, speakers and the power supply you can turn it on:

- Press and release the red 'STBY' button on the remote whilst aiming it at the amplifier.
- Press the button on the top left of the amplifier.
- Red light will turn off on the product

After a few seconds you should see the 'Micromega' logo appear on the displays.

To turn off your amplifier, use the same process.

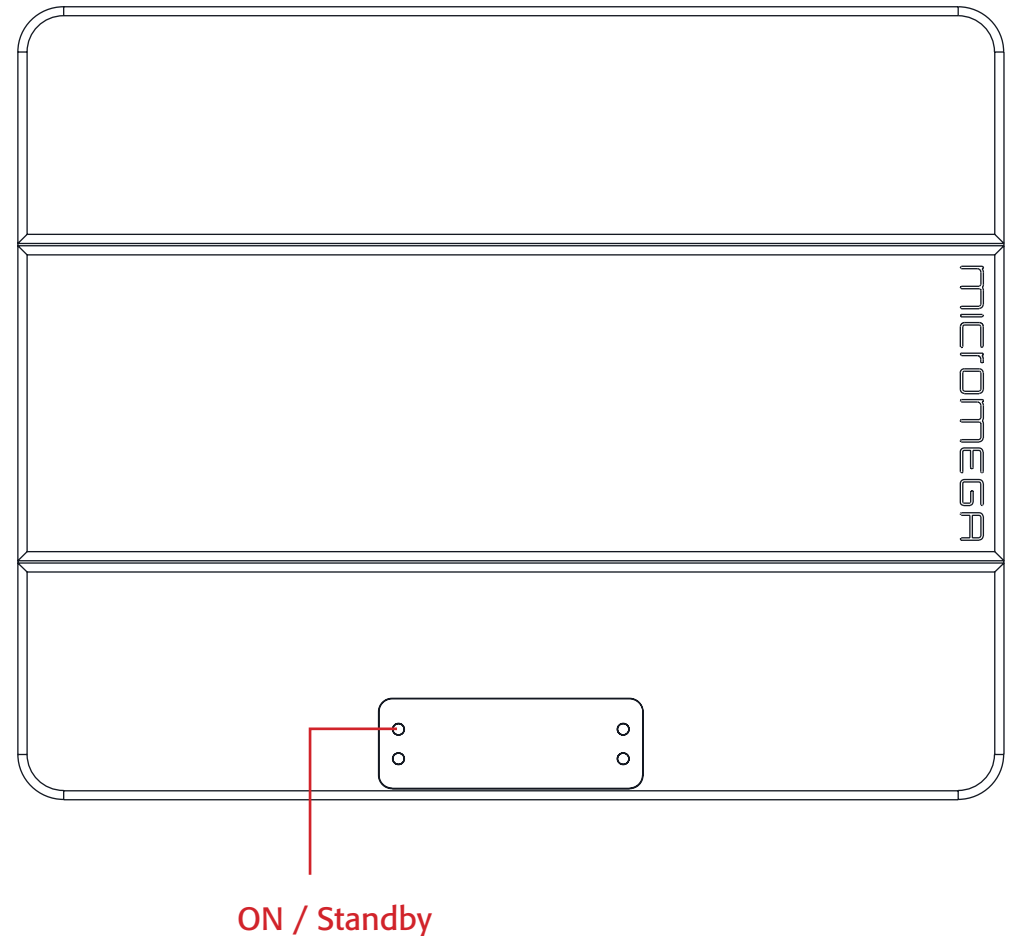

## 3.2 CHOOSING YOUR SOURCE

Point the infrared remote control at the device and use it to select your music source.

You can use the buttons at the top of the amplifier to do this if you prefer.

The main display (fig. 1) shows which input is active (USB), the volume (20) and any specifications of the input signal (only for digital signals).

To change the input source, press on the button at the bottom left.

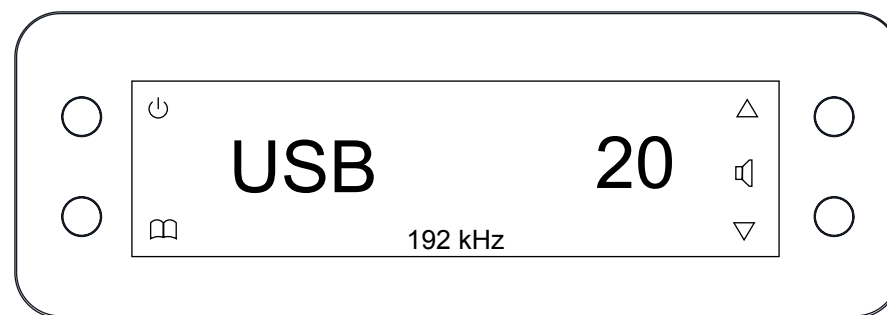

Fig. 1

A list of sources will now appear in place of the volume (fig. 2).

By using the up and down arrows you can select the desired source and confirm using the « OK » button.

If you change your mind and don't want to change the source, press the top left button ( « < » ) to return to the main display.



Fig. 2

### 3.3 ADJUSTING THE BALANCE

Adjusting the balance enables you to compensate for any dissymmetry in the two speakers related to your listening position. The volume can be adjusted to be louder on one side than the other (6dB on each side).

Adjusting the balance effects all sources.

From the main display (fig. 1), press on the button at the bottom left.

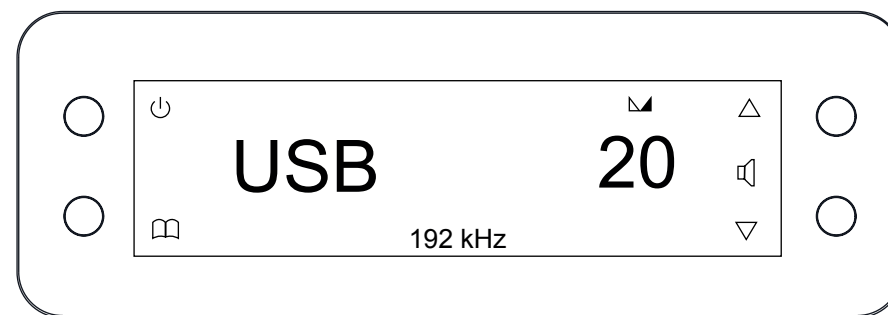

Fig. 1

Scroll through the list until 'BAL' (fig. 2) appears and confirm with 'OK'

A balance screen appears where you can make adjustments. You can confirm any adjustments by selecting 'OK' or cancel them using '<'. A triangle symbol on the right indicates an active balance setting.



Fig. 2

▴ symbolise there is an active balance setting (here to the right)

## 3.4 ADJUSTING SENSITIVITY

Adjusting sensitivity enables you to compensate for a signal level difference between your sources (+ or - 6 dB).

This adjustment is particular to each input. You should be connected to the source you wish to adjust before starting (in this example we are adjusting the LINE terminal).

From the main display (fig. 1), press on the button at the bottom left.

Scroll through the list until 'SENS' (fig. 2) appears and confirm with 'OK'

A sensitivity screen appears where you can make adjustments. You can confirm any adjustments by selecting 'OK' or cancel them using '<'.  
  
◆ symbolise there is an active sensitivity setting (here, sensitivity is lowered)

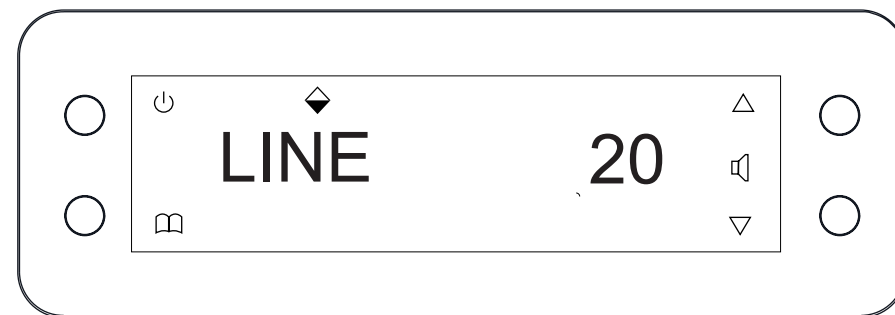

Fig. 1



Fig. 2

### 3.5 RENAMING THE SOURCES

For certain terminals (AES, OPTO, COAX, LINE, XLR) you can select from a predefined list of names.

From the main display (fig. 1), press on the button at the bottom left.

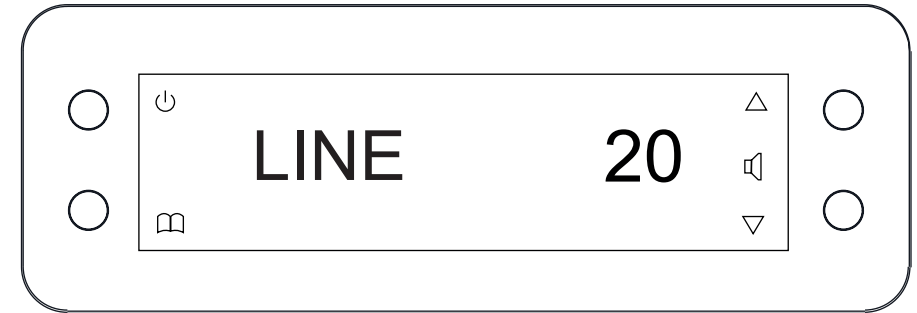

Fig. 1

Scroll through the list until 'NAME' (fig. 2) appears and confirm with 'OK'

Scroll through the list of predefined names and choose the name which you feel suits your source best.

You can confirm any adjustments by selecting 'OK' or cancel them using '<'.</p></div>

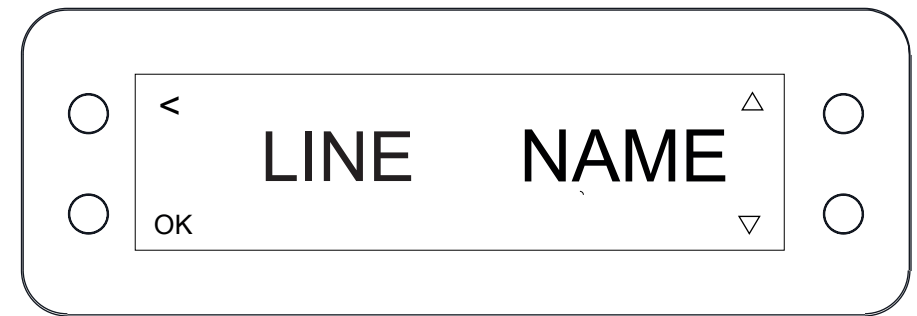

Fig. 2

**NB:** Renaming of all inputs can be done through the Micromega app

### 3.6 UPDATING THE M-100

Download the .zip folder which contains updates files on the M-One page of our website: <http://www.micromega.com>

#### Instructions for updates :

- Extract the downloaded .zip on your computer
- Copy « M-ONE-Vxx.img » onto a USB key (formatted in FAT)
- Turn off your M-100 and disconnect it from the mains.
- Insert the USB key 1 into port 1 at the back of the M-100
- Reconnect the mains, the update will start (fig.1)
- A few moments later, an 'update completed' message will appear (fig.2)
- Disconnect the mains, take out the USB key and reconnect the mains.
- Please wait one or two minutes to starting the network module correctly

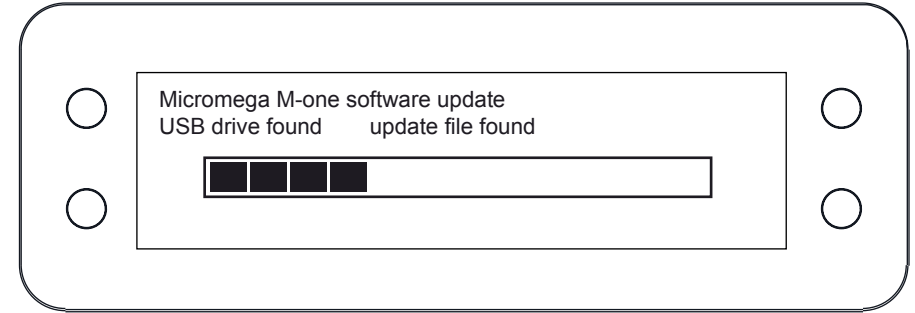

*Fig. 1*

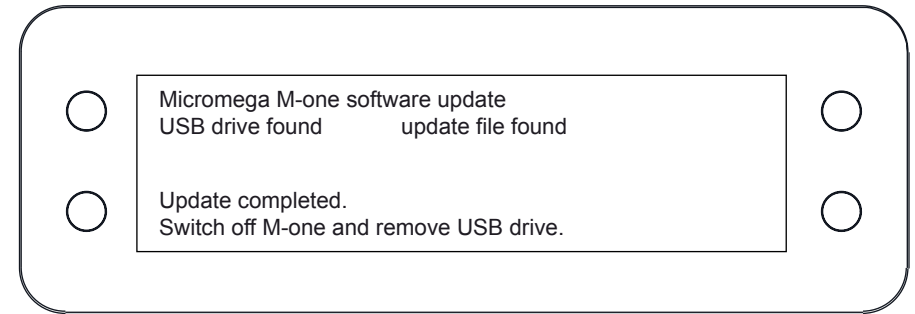

*Fig. 2*

**NB :** If a update is available, you should update to get the most out of your device.

## 3.7 UPDATING THE NETWORK MODULE

Download the .zip folder which contains updates files on the M-One page of our website: <http://www.micromega.com>

Instructions for updates :

- Extract the downloaded .zip on your computer
- On your M-One : go to INFO menu (fig. 1) and take note of the IP adress written on the second page (fig. 2)

If the IP adress is shown as « 000.000.000.000 », download the mobile application (available on Google Play & App Store). This app will list all the connected devices on your network. You must look the IP adress for « Audio Renderer» or «Micromega M-One».

- On your computer : write your IP adress in your browser navigation bar
- Follow the instructions to update the network module. Select the « NMR-Vxx.bin » file and validate

**NB :** If the update stuck on «Rebooting, please wait», press **STANDY** button for 6 seconds to reboot M-One. Power it again and wait one or two minutes to starting the network module

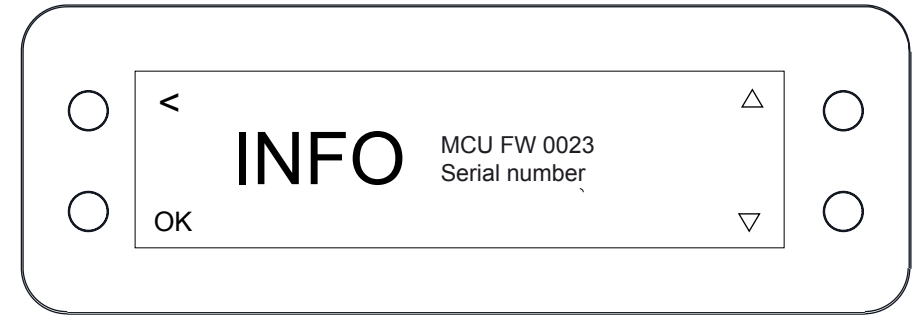

Fig. 1

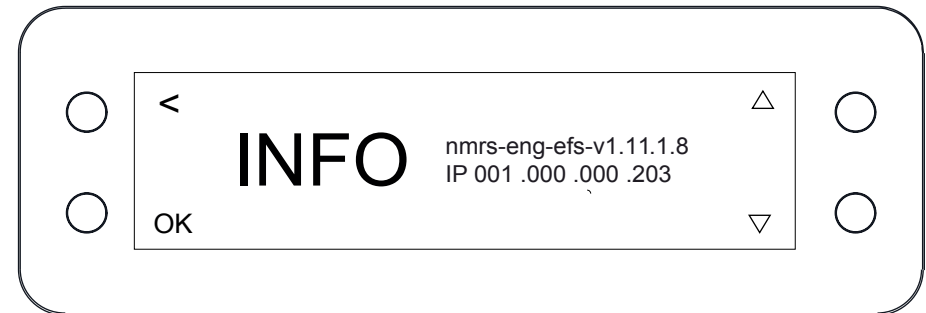

Fig. 2



## 4. SPECIFICATIONS

### Amplifier size

Width : 430 mm  
Depth : 350 mm  
Height (with spikes) : 56 mm

### Amplifier weight

Net weight : 9 kg  
Gross weight : 10,7 kg

### Packaging (box)

Width : 685 mm  
Depth : 542 mm  
Height : 85 mm

### Packaging (overbox)

Width : 735 mm  
Depth : 600 mm  
Height : 150 mm

### Power Consumption

Standby : 1W  
2 channels -1/8 Pmax under 8 Ohms : 140W

### Rated output power

P<sub>RMS</sub> under 8 Ohms : 2\*100W  
P<sub>RMS</sub> under 4 Ohms : 2\*200W

### Signal to noise ratio

Digital input : 106 dB(A)  
Balanced analog input : 103 dB(A)  
Unbalanced analog input : 100 dB(A)  
Phono MM input : Higher than 75 dB(A)

**Speaker output residual noise, open input**

8 Ohms : under 160  $\mu$ V  
4 Ohms : under 200  $\mu$ V

**Output impedance @250Hz under 8 Ohms** 15m $\Omega$

**Damping factor** Sup. à 500

**Total harmony distortion**

THD, 8 Ohms, 63 Hz : under 0,001%  
THD, 8 Ohms, 1 kHz : under 0,005%  
THD, 8 Ohms, 10 kHz : under 0,05%  
THD, 4 Ohms, 63 Hz : under 0,001%  
THD, 4 Ohms, 1 kHz : under 0,01%  
THD, 4 Ohms, 10 kHz : under 0,07%

**Intermodulation distortion - SMPTE**

IMD, from 1W to P<sub>NOM</sub>, 8 Ohms under 0,01%  
IMD, from 1W to P<sub>NOM</sub>, 4 Ohms under 0,02%

**Intermodulation distortion - Dynamic**

DIM 30, 50W, 8 Ohms under 0,02%  
DIM 30, 100W, 4 Ohms under 0,05%

### **Channels separation**

Crosstalk, 1kHz

under 96dB

Crosstalk, 10kHz

under 80dB

### **Analog input sensitivity**

Phono MM, 47 kOhms

12 mVRMS

Phono MC, 110 Ohms

1,2 mVRMS

Analogue :

1,4 VRMS

Balanced :

1,7 VRMS

### **Sub-out output**

Cut-off frequency :

400 Hz



# MICROMEGA

Le son de France

AUDIS MICROMEGA

13-15 rue du 8 Mai 1945

94470 Boissy-Saint-Léger

FRANCE

[contact@micromega.com](mailto:contact@micromega.com)

<http://www.micromega.com>

<http://facebook.com/micromegahifi>